

BTF060



 **FERNETO**



CC\_006-6

## PLANETARY MIXER 60 LITERS

Bowl capacity (l)	60
Emulsion (l)	15
Creams without emulsion (l)	30
Creams with emulsion (l)	18
Bread dough (flour)* (Kg)-(lb)	12 (26,46)
Shortcrust pastry (dough) * (Kg)-(lb)	18 (39,68)
Power (kW)-(hp) 230V-1ph-50/60Hz 230V-3ph-50/60Hz 400V-3ph-50/60Hz	3 (4) 2,2 (3) 2,2 (3)
Power lifting (kW)-(hp) 230V-1ph-50/60Hz 230V-3ph-50/60Hz 400V-3ph-50/60Hz	0,25 (0,3) 0,25 (0,3) 0,25 (0,3)
Hub attachment power (kW)-(hp) 230V-1ph-50/60Hz 230V-3ph-50/60Hz 400V-3ph-50/60Hz	0,55 (0,75) 0,55 (0,75) 0,55 (0,75)
Net weight (Kg)-(lb)	215 (473,99)
Dimensions (mm)-(in)	A 630 (24 13/16) B 950 (37 3/8) C 1440 (56 11/16)



\* Based on: 60% dough hydration, 125 flour moisture, 2°C water

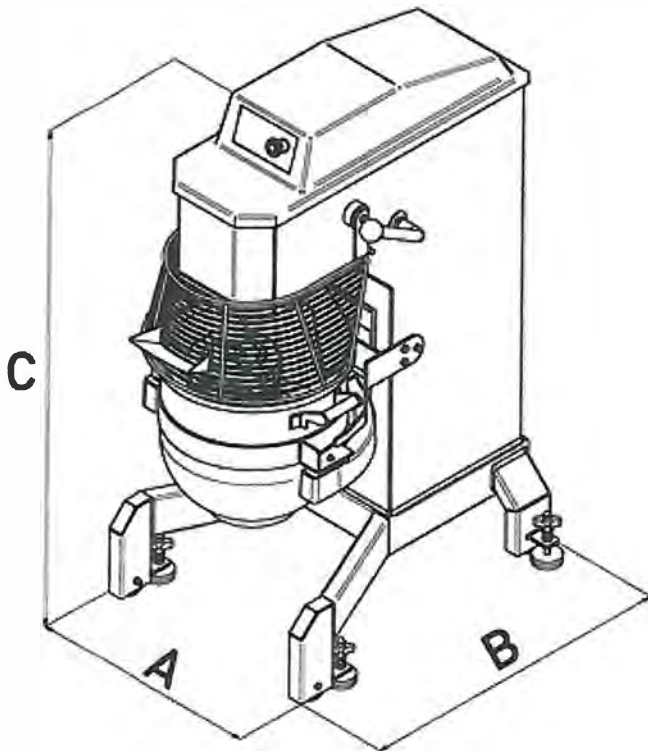

**Reward  
Hospitality**

Contact our team for enquiries.

Commercial: 0800 428 733 | Domestic Products: 0800 697 465 | Service: 0800 178 349

[www.rewardhospitality.co.nz](http://www.rewardhospitality.co.nz)